

**BELLOW VALVE zBEL**



Body material	Nominal pressure	Nominal diameter	Max. temperature
<b>A</b> Grey cast iron	<b>C</b> 16 bar	<b>DN</b> <b>15-250</b>	300°C
<b>C</b> Nodular cast iron	<b>C</b> 16 bar <b>D</b> 25 bar	<b>DN</b> <b>15-200</b>	350°C
<b>F</b> Cast steel	<b>E</b> 40 bar	<b>DN</b> <b>15-200</b>	450°C
<b>I</b> Cast stainless steel	<b>E</b> 40 bar	<b>DN</b> <b>15-200</b>	400°C



correspond to the pressure equipment directive 2014/68/UE marking CE for DN≥32

**FEATURES**

- high tightness (leakproofness class - A acc. EN -12266 - 1)
- compact settlement
- environment-friendly
- tests acc. EN - 12266 - 1
- flanges drilled according to EN 1092-2 for body material A, C, E
- flanges drilled according to EN 1092-1 for body material F, I
- face-to-face dimension according to EN 558 series 1

**APPLICATION \***

\*not all of the applications are suitable for all of the executions

industries						
	INDUSTRY	SHIPBUILDING INDUSTRY	HEATING	REFRIGERATION AND AIR CONDITIONING		
media						
	GLYCOL	INDUSTRIAL WATER	DIATHERMIC OIL	STEAM	COMPRESSED AIR	NEUTRAL FLUIDS

Data given can be changed without notice.

Edition 01/2018

FIG.234

MATERIALS, DIMENSIONS

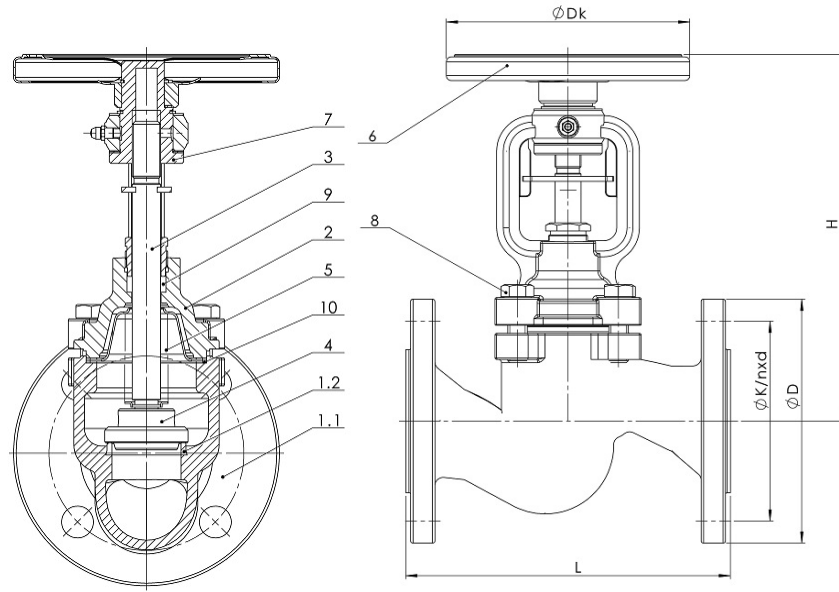

	Body material	A	C
	Type	01; 04; 71	01; 04; 71
1.1	Body	EN – GJL-250 5.1301 (ex. J11040)	EN – GJS-400 – 18-LT 5.3103 (ex. JS1025)
1.2	Seat ring	X12Cr13 1.4021	
2	Bonnet	EN – GJS-400 – 18-LT 5.3103 (ex. JS1025)	
3	Stem	X20Cr13 1.4021	
4	Disc	X20Cr13+QT 1.4021	
5	Bellow	X6CrNiMoTi-17-12-2	
6	Hand-wheel	Steel	
7	Sleeve	11SMnPb30	
8	Hexagon bolt	5.6	A2-70
9	Gland packing	Graphite	
10	Bonnet gasket	Graphite + CrNiSt	
Max. temperature		300°C	350°C

DN		15	20	25	32	40	50	65	80	100	125	150	200	250
L (mm)		130	150	160	180	200	230	290	310	350	400	480	600	730
Dk (mm)		125	125	125	125	150	150	175	200	250	300	400	500	600
H		178	178	193	201	224	228	270	295	325	380	427	569	645
K <sub>vs</sub> (m <sup>3</sup> /h)	01;04	5,9	7,4	13	18	30	41	79	115	181	225	364	725	-----
	71	3,4	6,3	9,4	16	26	40	70	106	170	245	360	-----	-----
Weight (kg)	01;04	3,2	3,9	4,85	6,5	9,0	11	15,8	24,3	35	49	76	130,5	210
	71	3,2	3,9	5,0	6,7	9,3	11,5	16,3	21,4	36	51,5	78	130,5	-----

Data given can be changed without notice.

Edition 01/2018

FIG.234

MATERIALS, DIMENSIONS

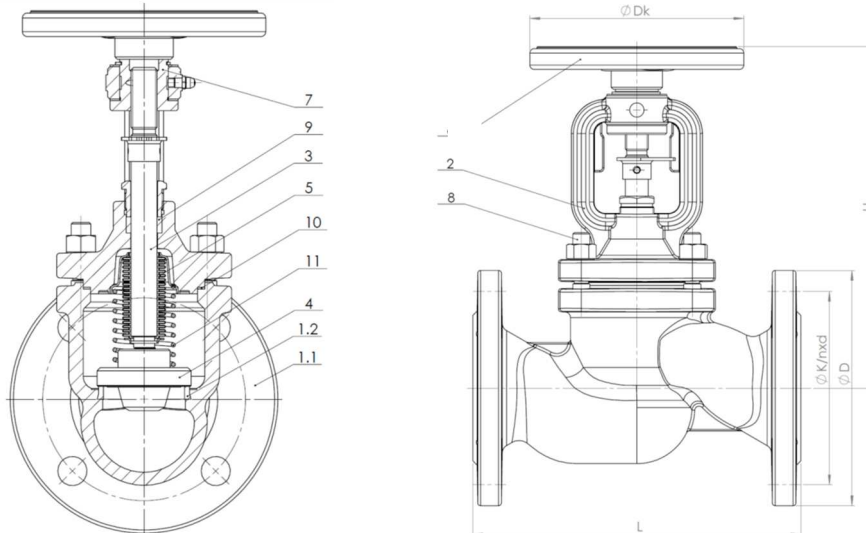

Body material		F			
Type	01; 11	14	31 ; 30	71	
1.1 Body	GP240GH				
1.2 Seat	X20Cr13 1.4021/ stellite				
2 Bonnet	GP240GH				
3 Stem	X20Cr13 1.4021				
4 Disc	X20Cr13+QT 1.4021	balancing disc X20Cr13+QT 1.4021	SDNR X20Cr13+QT 1.4021	throttling disc X20Cr13 +QT 1.4021	
5 Bellow	X6CrNiMoTi17-12-2				
6 Hand-wheel	cast iron				
7 Sleeve	11SMnPb30				
8 Stud bolt, nut	24CrMo4, C35E				
9 Gland packing	graphite				
10 Bonnet gasket	graphite + CrNiSt				
11 Spring	----	----	1.4057	----	
Max. temperature	450°C				

DN	15	20	25	32	40	50	65	80	100	125	150	200
L (mm)	130	150	160	180	200	230	290	310	350	400	480	600
Dk (mm)	125	125	125	125	200	200	250	250	300	300	400	400
H (mm)	190	190	190	195	240	240	270	300	450	520	570	627
K <sub>vs</sub> (m <sup>3</sup> /h)	6,0	8,7	15,5	25,3	28,8	46,5	76,4	113,2	180,2	238,7	358,2	552
Weight (kg)	4,3	5,1	6,0	7,6	11,5	13,7	20,1	27,5	44,0	65,5	110,0	172,5

Data given can be changed without notice.

Edition 01/2018

E-mail szolnok@oktogonal.hu

FIG.234

**MATERIALS, DIMENSIONS**

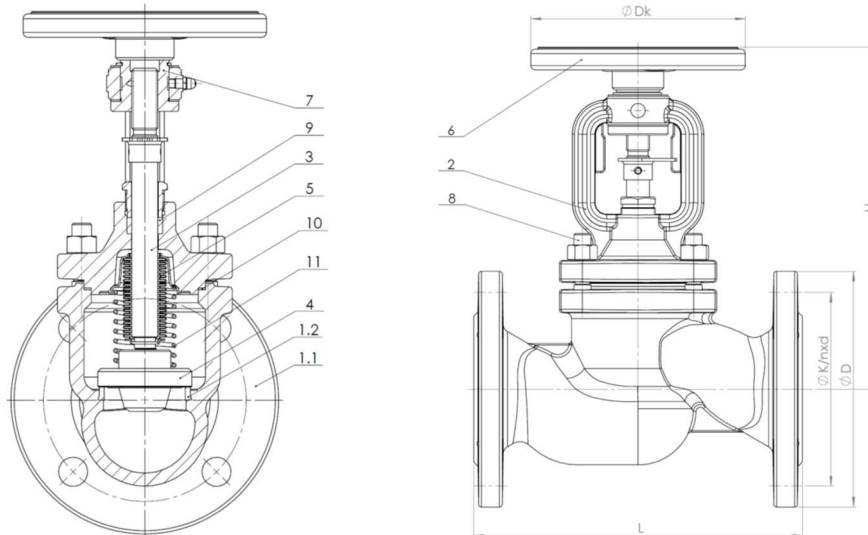

Body material		I		
Type	10; 12	09	40; 39	
1.1	Body	G-X5CrNiMo19-11-2 1.4408		
1.2	Seat	X5CrNiMo17-12-2 1.4401/ stellite		
2	Bonnet	G-X5CrNiMo19-11-2 1.4408		
3	Stem	X6CrNiMoTi17-12-2 1.4571		
4	Disc	X6CrNiMoTi17-12-2 1.4571	balancing disc X20Cr13 1.4021	SDNR X20Cr13 1.4021
5	Bellow	X6CrNiMoTi17-12-2 1.4571		
6	Hand-wheel	Steel		
7	sleeve	11SMnPb30		
8	Bolt, nut	A4-70; A4		
9	Gland packing	Graphite		
10	Bonnet gasket	Graphite + CrNiSt		
11	Spring	----		X17CrNi16-2 1.4057
Max. temperature		400°C		

DN	15	20	25	32	40	50	65	80	100	125	150	200
L (mm)	130	150	160	180	200	230	290	310	350	400	480	600
Dk (mm)	125	125	125	125	200	200	250	250	300	300	400	400

Data given can be changed without notice.

Edition 01/2018

E-mail szolnok@oktogonal.hu  
www.oktogonal.hu

FIG.234

H (mm)	190	190	190	195	240	240	270	300	450	520	570	627
Weight (kg)	3,8	4,9	5,7	7,4	10,7	13,1	19,5	25,7	43,9	64,8	95,0	152,0

**PRESSURE-TEMPERATURE RATINGS**

PN		---	-10°±120°C	150°C	200°C	250°C	300°C	350°C	400°C	450°C		
EN-GJL-250	16	bar	---	16	14,4	12,8	11,2	9,6	---	---		
EN-GJS-400-18 LT	16		---	16	15,5	14,7	13,9	12,8	11,2	---		
	25		---	25	24,3	23	21,8	20	17,5	---		
<b>Acc. EN 1092-1</b>			<b>-20°÷&lt;-10°C</b>	<b>-10°÷50°C</b>	<b>100°C</b>	<b>150°C</b>	<b>200°C</b>	<b>250°C</b>	<b>300°C</b>	<b>350°C</b>	<b>400°C</b>	<b>450°C</b>
GP240GH	40	bar	30	40	37,1	35,2	33,3	30,4	27,6	25,7	23,8	13,1
<b>Acc. EN 1092-1</b>			---	<b>-60°÷&lt;-10°C</b>	<b>-10°C÷100°C</b>	<b>150°C</b>	<b>200°C</b>	<b>250°C</b>	<b>300°C</b>	<b>350°C</b>	<b>400°C</b>	<b>450°C</b>
G-X5CrNiMo19-11-2	40		---	40	40	36,3	33,7	31,8	29,7	28,5	27,4	---

**FLANGE DIMENSIONS ACC. PN-EN 1092-1/-2**

DN		15	20	25	32	40	50	65	80	100	125	150	200	250
PN6	D (mm)	80	90	100	120	130	140	160	190	210	240	265	320	-----
	K (mm)	55	65	75	90	100	110	130	150	170	200	225	280	-----
	nxd (mm)	4x11	4x11	4x11	4x14	4x14	4x14	4x14	4x14	4x18	4x18	8x18	8x18	8x18
PN16	D (mm)	95	105	115	140	150	165	185	200	220	250	285	340	405
	K (mm)	65	75	85	100	110	125	145	160	180	210	240	295	355
	nxd (mm)	4x14	4x14	4x14	4x19	4x19	4x19	4x19	8x19	8x19	8x19	8x23	12x23	12x28
PN25	D (mm)	95	105	115	140	150	165	185	200	235	270	300	360	-----
	K (mm)	65	75	85	100	110	125	145	160	190	220	250	310	-----
	nxd (mm)	4x14	4x14	4x14	4x19	4x19	4x19	8x19	8x19	8x23	8x28	8x28	12x28	-----
PN40	D (mm)	95	105	115	140	150	165	185	200	235	270	300	375	-----
	K (mm)	65	75	85	100	110	125	145	160	190	220	250	320	-----
	nxd (mm)	4x14	4x14	4x14	4x18	4x18	4x18	8x18	8x18	8x22	8x26	8x26	12X30	-----

**DISC**

type 01, 11, 10, 12      type 04, 14, 09      type 31, 40, 30, 39      type 71

FIG.234

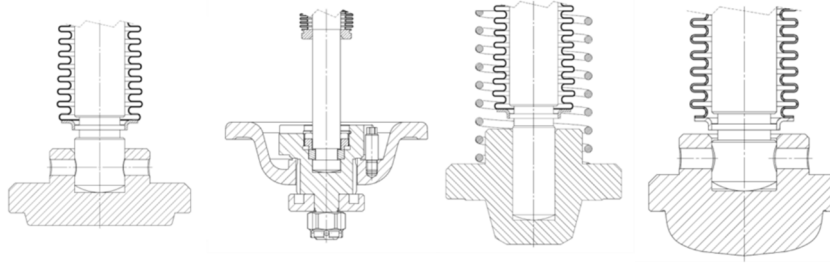

TYPE

Figure	Body material	Nominal diameter	Nominal pressure	Type
234	A Grey cast iron EN-GJL-250	15-150 mm	C 16 bar	01 stem connected with bellow; stem, disc, bellow and seat ring - stainless steel
		200-250 mm	C 16 bar	04 stem connected with bellow; stem, balancing disc; bellow and seat ring - stainless steel
		15-200 mm	C 16 bar	71 stem connected with bellow; stem, throttling disc; bellow and seat ring - stainless steel
234	C Nodular cast iron EN-GJS-400-18-LT	15-150 mm	C 16 bar	01 stem connected with bellow; stem, disc, bellow and seat ring - stainless steel
		200 mm	C 16 bar	04 stem connected with bellow; stem, balancing disc; bellow and seat ring - stainless steel
		15-200 mm	C 16 bar	71 stem connected with bellow; stem, throttling disc; bellow and seat ring - stainless steel
		15-150 mm	D 25 bar	01 stem connected with bellow; stem, disc, bellow and seat ring - stainless steel
		200 mm	D 25 bar	04 stem connected with bellow; stem, balancing disc; bellow and seat ring - stainless steel
		15-200 mm	D 25 bar	71 stem connected with bellow; stem, throttling disc; bellow and seat ring - stainless steel
234	F Cast steel GP240GH 1.0619	15-50 mm	E 40 bar	01 stem connected with bellow; stem, disc; bellow and seat ring - stainless steel
		65-100 mm	E 40 bar	11 stem connected with bellow; stem, disc; bellow - stainless steel ; seat - Stellite
		125-200 mm	E 40 bar	14 stem connected with bellow; stem, balancing disc, bellow - stainless steel ; seat - Stellite
		15-50 mm	E 40 bar	31 stem connected with bellow; lose disc with spring; stem, disc, spring, bellow - stainless steel; seat ring - stainless steel
		65-200 mm	E 40 bar	30 stem connected with bellow; lose disc with spring; stem, disc, spring, bellow - stainless steel; seat - Stellite
		15-200 mm	E 40 bar	71 stem connected with bellow; stem, throttling disc, bellow - stainless steel; seat - stainless steel/Stellite
234	I Cast stainless steel G-X5CrNiMo19-11-2	15-50 mm	E 40 bar	10 stem connected with bellow; stem, disc; bellow and seat ring - stainless steel
		65-100 mm	E 40 bar	12 stem connected with bellow; stem, disc; bellow - stainless steel ; seat - Stellite

Data given can be changed without notice.

Edition 01/2018

**FIG.234**

125-200 mm	E 40 bar	09 stem connected with bellow; stem, balancing disc, bellow - stainless steel ; seat - Stellite
15-50 mm	E 40 bar	40 stem connected with bellow; lose disc with spring; stem, disc, spring, bellow - stainless steel; seat ring - stainless steel
65-200 mm	E 40 bar	39 stem connected with bellow; lose disc with spring; stem, disc, spring, bellow - stainless steel; seat - Stellite

**ORDERING**

Figure	Body material	Nominal diameter	Nominal pressure	Type
234	A Grey cast iron EN-GJL-250	15-150 mm	C 16 bar	01 stem connected with bellow; stem, disc, bellow and seat ring - stainless steel

Order example acc. index

234 A 050 C 01

Bellow sealed stop valves, ends flanged, form straight  
 Grey cast iron EN-GJL-250  
 Nominal diameter (mm)  
 Nominal pressure PN 16  
 Stem connected with bellow; stem, disc and seat ring stainless steel

234 A 050 C 01